



# NEO<sup>2</sup>

OEM  
HVAC

## 3 SPEED VENTILATION AND TEMPERATURE BY COMPRESSOR CYCLING CONTROL PANEL GL-P8HGL207

### CHARACTERISTICS

- 3 speed evaporator power switch 16A@12V and 10A@24V
- Return temperature sensor
- Celcius scale
- Fresh air output
- 5A positive clutch output
- A/C button
- Fresh air button
- Diagnostic LED
- Innovative design
- Designed for heavy-duty applications
- Analog commands
- Backlit buttons and symbols
- Customer logo on the panel (optional)
- Screwless installation
- Automotive connector
- High frontal protection grade- IP 54

### TECHNICAL DATA

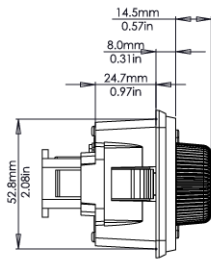
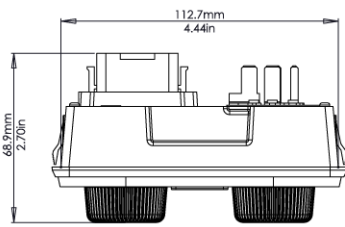

Approximate gross weight: 175 g

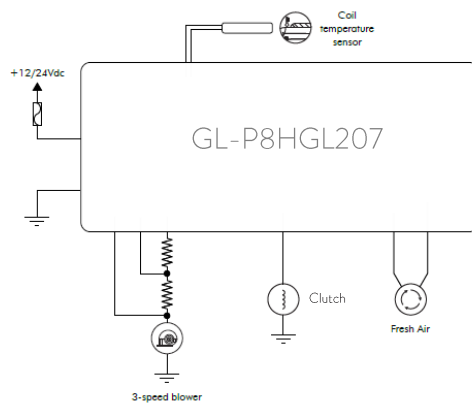

### CONNECTORS



3 Speed Power switch  
Part Number: 754C3  
Manufacturer: KOCH SALES



Mate-N-Lok 15 cable paths  
Part Number: 1-480710 - 0  
Terminal - PN: 350689-3  
Manufacturer: Tyco Electronics

### TECHNICAL DATA

OPERATING VOLTAGE	12 Vdc to 24 Vdc
VOLTAGE RANGE	9 Vdc to 30 Vdc
MAXIMUM VOLTAGE	32 Vdc during 5min
MAXIMUM OUTPUT CURRENT	See description above
OUTPUT SHORT CIRCUIT	Protected ***
REVERSE POLARITY	Protected *
OPERATING TEMPERATURE	-40°C to +85°C / -40°F to +185°F
STORAGE TEMPERATURE	-40°C to +125°C / -40°F to +257°F
TEMPERATURE SENSOR	NTC 10K
FRONTAL PROTECTION DEGREE	IP 54
COMMUNICATION	N/A
MAXIMUM CURRENT CONSUMPTION	40mA @ 12Vdc, 20mA @ 24Vdc **

\* According to product specifications.

\*\* Consumption ,may vary according to customer specifications.

\*\*\* Except on power switch.

We keep the right to update or change information regarding products without prior notice.