



TWISTER

OEM
HVAC

AIR CONDITIONING CONTROL PANEL WITH GRAPHIC DISPLAY GL-P4HGL003

CHARACTERISTICS

- Refrigeration, heating and AUTO modes
- 3 speed fan, clutch and fresh air output
- External Temperature Sensor (optional)
- Pressure Switch
- Customizable design
- 6 backlit buttons keyboard
- Backlit graphic display - 128x96px
- Configurable parameters
- Failure indication on display
- Customer logo on display (optional)

CONNECTORS



MICRO-FIT
06 ways for cable - PN: 662006113322
Terminal - PN: 66210113722
Manufacturer: WÜRTH



MICRO-FIT
08 ways for cable - PN: 662006113322
Terminal - PN: 66210113722
Manufacturer: WÜRTH

TECHNICAL DATA

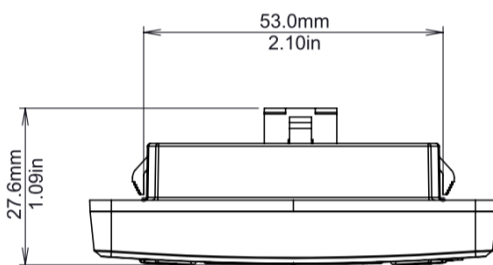
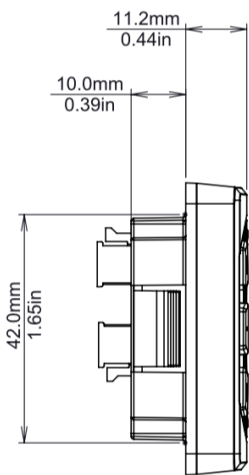

Approximate gross weight: 60 g

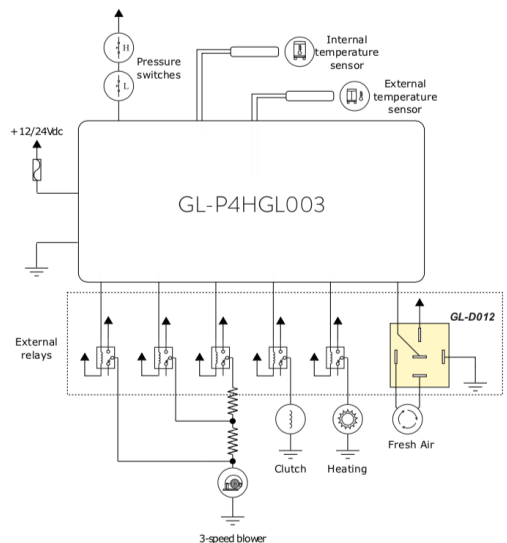

TECHNICAL DATA

OPERATING VOLTAGE	12 Vdc to 24 Vdc
VOLTAGE RANGE	10 Vdc to 30 Vdc
MAXIMUM VOLTAGE	32 Vdc during 5mins.
MAXIMUM CURRENT PER OUTPUT	500mA
OUTPUT SHORT-CIRCUIT	Protected
REVERSE POLARITY	Protected
OPERATING TEMPERATURE	-30°C to +85°C / -22°F to +185°F
STORAGE TEMPERATURE	-40°C to +85°C / -40°F to +185°F
TEMPERATURE SENSOR	NTC 10K@25°C/77°F
FRONTAL PROTECTION DEGREE	IP 54
COMMUNICATION	N/A
MAXIMUM CURRENT CONSUMPTION	30mA *
STANDBY CONSUMPTION	10mA *

* Consumption may vary according to customer specifications.
We keep the right to update or change information regarding products without prior notice.